

# Euro Twin Bar Lite

Cat. No. ETBL

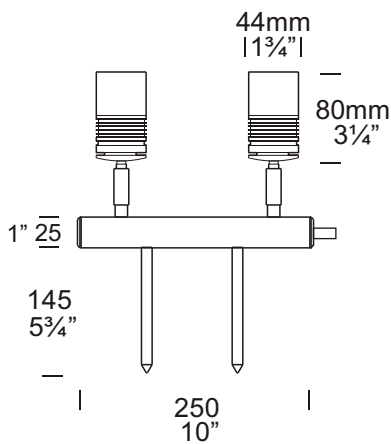

The Euro Twin Bar Lite is an extra compact luminaire designed for situations where the fixture needs to be very obtrusive or concealed. This luminaire has two individual spotlights which can be aimed in two entirely different directions and are ideal for illuminating bushes, trees or any landscape features. Each lite has a fully adjustable arm allowing 360 degree rotation and 0 - 90 degree elevation adjustment. The heads are mounted on a 250mm (10") bar with twin ground spikes.



## Ordering Information

Luminaire Type	Material	Accessories
ETBL - Euro Twin Bar Lite	COP - Copper SS - 316 Stainless Steel	CJK150 - Cable Joint Kit LENSEURF - Frosted Lens /300 - 300mm (12") Spike For an alternative LED option start at page 10.4

Ordering Example: ETBL COP - Euro Twin Bar Lite in Copper

ETBL/300 SS - Euro Twin Bar Lite in 316 Stainless Steel 300mm (12") Spike

(Accessories ordered separately)

**HUNZA**™ PURE OUTDOOR LIGHTING

**HUNZA FACTORY**  
130 Felton Mathew Ave  
Glen Innes  
Auckland 1072  
New Zealand

Ph: 64-9-528 9471  
Fax: 64-9-528 9361  
hunza@hunza.co.nz  
www.hunza.co.nz

**INTERNATIONAL CONTACTS:**  
[www.hunza.co.nz/contacts.php](http://www.hunza.co.nz/contacts.php)

Specifications may change without notice.  
Manufactured in New Zealand.

© 2009 Hunza Holdings Ltd.

Ver 1.4

## Luminaire Construction

CNC machined from one of the following metals:

### Copper:

Body 45.4mm (1¾") rod.

### Bar:

25.4mm x 1.42mm (1" x 1/16") tube.

### End Cap:

25.4mm x 10 mm (1" x 3/8") brass rod.

### Spike:

11mm x 150mm (3/8" x 6") copper.

### 316 Stainless Steel:

#### Body:

45.4mm (1¾") rod.

#### Bar:

25.4 x 1.42mm (1" x 1/16") tube.

#### End Cap:

25.4mm x 10mm (1" x 3/8") rod.

#### Spike:

11mm x 150mm (3/8" x 6") rod.

## Mounting

Spike 150mm (6") 300mm (12") mounted directly into the ground.

## Features

### Lens:

6mm (¼") clear flush fit shatter resistant glass with Hex Cell Louvre for glare control.

Life Time Warranty.

### Gaskets:

Silicone, iron impregnated 220°C (428°F).

### Lamp Holders:

GU4 - 350°C (662°F) ceramic multi contact lamp holder with 250°C (480°F) teflon cables.

### Accessories:

Cable Joint Kit (Cat. CJK150).  
Not approved for USA/Canada.  
Frosted Lens (Cat. LENSEURF).  
Ground Spike 300mm (12") (Cat. /300).

### Swivels:

Copper luminaires - 360° rotation and 0 - 90° elevation, solid brass with anti rust spring.

Stainless Steel luminaires - 360° rotation and 0 - 90° elevation, full stainless steel construction.

## Standards

IP66



UL1838

## Luminaire Weight

Cop 2.840kg (6lb 4oz)  
SS 2.414kg (5lb 5oz)

## Power Supply

HUNZA™ Inground or Wall Mount  
Transformer: not included.

USA and Canada:

HUNZA™ Wall Mount Transformer:  
not included.

## Lamp Type

MR11 GU4 - 2 x 20 watt lamps max

**LED** - Refer sheet no. 10.4

USA and Canada:

MR11 GU4 - 2 x 10 watt lamps max

**LED** - Refer sheet no. 10.4

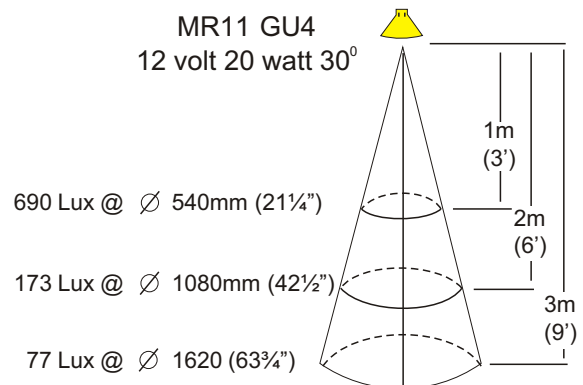
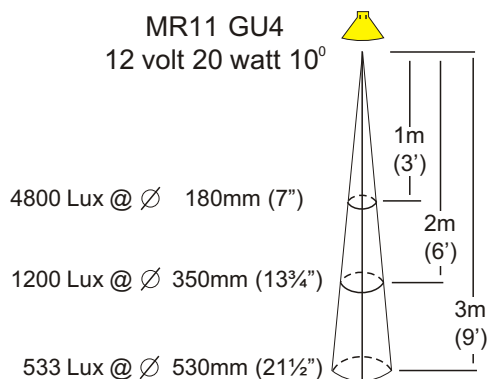

**HUNZA**™ PURE  
OUTDOOR  
LIGHTING

**HUNZA FACTORY**  
130 Felton Mathew Ave  
Glen Innes  
Auckland 1072  
New Zealand

Ph: 64-9-528 9471  
Fax: 64-9-528 9361  
hunza@hunza.co.nz  
www.hunza.co.nz

**INTERNATIONAL CONTACTS:**  
www.hunza.co.nz/contacts.php

Specifications may change without notice.  
Manufactured in New Zealand.

© 2009 Hunza Holdings Ltd.

Ver 1.4